



Drum Sander
American 12
Operator's Manual

READ THIS BOOK

This book has important information for the use and safe operation of this machine. Failure to read this book prior to operating or attempting any service or maintenance procedure to your American Sanders machine could result in injury to you or to other personnel; damage to the machine or to other property could occur as well. You must have training in the operation of this machine before using it. If your operator(s) cannot read this manual, have it explained fully before attempting to operate this machine.

All directions given in this book are as seen from the operator's position at the rear of the machine.

Contents

Operator Safety Instructions.....	2
Introduction and Machine Specifications.....	6
230V Electrical Connection Instructions.....	7
How to Transport the Machine.....	8
Machine Set-Up.....	9
How to Operate the Machine.....	10
Sanding Cuts and Sandpaper.....	13
Sander Adjustment Procedures.....	13
Routine Maintenance.....	15
Troubleshooting.....	16

SECTION II - Parts and Service Manual

Handle Assy [Models 07108A, 07109A, 07204A].....	18-19
Handle Assy [Model 07001A].....	20-21
Handle Assy [Model 07120A].....	22-23
Motor Assy [Model 07001A].....	24
Motor Assy [Models 07108A, 07109A, 07204A].....	25
Motor Assy [Model 07120A].....	26
Drum Assy.....	27
Dust Control Assy.....	28-29
Base Assy	30-31
Base Assy [Models 07044C, 07049C].....	32-33
Belt Guard Assy [Models 07108A, 07109A, 07204A].....	34
Belt Guard [Model 07001A].....	35
Belt Guard [Model 07120A].....	36
Accessories.....	37
Wiring Diagrams.....	38-39
Chatter-Wave Preventio.....	40-41

WARNING!

The Products sold with this Manual contain or may contain chemicals that are known to certain governments (such as the State of California, as identified in its Proposition 65 Regulatory Warning Law) to cause cancer, birth defects or other reproductive harm. In certain locations (including the State of California) purchasers of these Products that place them in service at an employment job site or a publicly accessible space are required by regulation to make certain notices, warnings or disclosures regarding the chemicals that are or may be contained in the Products at or about such work sites. It is the purchaser's responsibility to know the content of, and to comply with, any laws and regulations relating to the use of these Products in such environments. The Manufacturer disclaims any responsibility to advise purchasers of any specific requirements that may be applicable to the use of the Products in such environments.

*****This product is intended for commercial use only*****















Operator Safety Instructions

In this Operation Manual you will find three statements that you must read and observe to ensure safe operation of this machine.

DANGER means: Severe bodily injury or death can occur to you or other personnel if the **DANGER** statements found on this machine or in this Operation Manual are ignored or are not adhered to. Read and observe all **DANGER** statements found in this Operation Manual and on your machine.

WARNING means: Injury can occur to you or to other personnel if the **WARNING** statements found on your machine or in the Operation Manual are ignored or are not adhered to. Read and observe all **WARNING** statements found in this Operation Manual and on your machine.

CAUTION means: Damage can occur to the machine or to other property if the **CAUTION** statements found on your machine or in this Operation Manual are ignored or are not adhered to. Read and observe all **CAUTION** statements found in this Operation Manual and on your machine.

-  **DANGER:** Failure to read the Owner's Manual prior to operating or servicing your American Sanders machine could result in injury to you or to other personnel; damage to the machine or to other property could occur as well. You must have training in the operation of this machine before using it. If you or your operator(s) cannot read English, have this manual explained fully before attempting to operate this machine.  
-  **DANGER:**  A. Sanding/finishing wood floors can create an explosive or combustible environment. Do not operate this machine around solvents, thinners, alcohol, fuels, floor finishes, wood dust or any other flammable materials. Cigarette lighters, pilot lights, electrical sparks and all other sources of ignition should be extinguished or avoided. Keep work area well ventilated.
B. Dust generated from sanding wood floors can spontaneously ignite or explode. Promptly dispose of any sanding dust in a metal container clear of any combustibles. Do not dispose in a fire.
-  **DANGER:**  A. Electrocutation could occur if the machine is being serviced while the machine is connected to a power source. Disconnect the power supply before servicing.
B. Electrocutation or fire could occur if the machine is being operated with a damaged power cord. Keep the power cord clear of the pad. Always lift the cord over the machine. Do not move the machine by the power cord.
C. Shock hazard. Do not use the machine if it has been rained on or sprayed with water.
-  **DANGER:**  To avoid injury keep hands, feet, and loose clothing away from all moving parts on the machine. Disconnect the power cord before replacing the pad, changing the abrasive, or when servicing. Do not operate the machine unless all guards are in place. Never leave the machine unattended while connected to a power source.
-  **WARNING:**  Injury can occur if protective clothing or equipment is not used while sanding. Always wear safety goggles, protective clothing, and dust mask while sanding.
-  **WARNING:**  This sander is not to be used on pressure treated wood. Some pressure treated woods contain arsenic and sanding pressure treated wood produces hazardous dust. Inhaling hazardous dust from pressure treated wood can cause serious injury or death. Sanding pressure treated wood decks or uneven surfaces can damage the sander which is not covered under warranty or damage waiver.
-  **WARNING:** Any alterations or modifications of this machine could result in damage to the machine or injury to the operator or other bystanders. Alterations or modifications not authorized by the manufacturer voids any and all warranties and liabilities.
-  **WARNING:** Risk of explosion. Floor sanding can result in an explosive mixture of fine dust and air. Use floor sanding machine only in a well-ventilated area free from any flame or match.

General Power Tool Safety Warnings

WARNING: Read all safety warnings and instructions. Failure to follow warnings and instructions may result in electric shock, fire and or serious injury.

Save all warnings and instructions for future use.

The term "power tool" in the warnings refers to your main-operated (corded) power tool or battery operated (cordless) power tool.

1) Work area safety

- Keep work area clean and well lit.** Clutter or dark areas invite accidents .
- Do not operate power tools in explosive atmospheres, such as in the presence of flammable liquids, gasses, or dust.** Power tools create sparks which may ignite the dust or fumes.
- Keep children and bystanders away while operating a power tool.** Distractions can cause you to lose control.

2) Electrical safety

- Power tool plugs must match the outlet. Never modify the plug in any way. Do not use any adapter plugs with earthed (grounded) power tools.** Unmodified plugs and matching outlets will reduce risk of electric shock .
- Avoid body contact with earthed or grounded surfaces such as pipes, radiators, ranges, and refrigerators.** There is an increased risk of electric shock if your body is earthed or grounded .
- Do not expose power tools to rain or wet conditions.** Water entering a power tool will increase the risk of electric shock.
- Do not abuse the cord. Never use the cord for carrying, pulling or unplugging the power tool. Keep cord away from heat, oil, sharp edges or moving parts.** Damaged or entangled cords increase the risk of electric shock.
- When operating a power tool outdoors, use an extension cord suitable for outdoor use.** Use of cord suitable for outdoor use reduces the risk of electric shock .

- f) **If operating a power tool in a damp location is unavoidable, use a residual current device (RCD) or ground fault circuit interrupter (GFCI) protected supply.** Use of a RCD or GFCI reduces the risk of electric shock .

3) Personal safety

- a) **Stay alert, watch what you are doing and use common sense when operating a power tool. Do not use a power tool while you are tired or under the influence of drugs, alcohol, or medication.** A moment of inattention while operating power tools may result in serious personal injury.
- b) **Use personal protective equipment. Always wear eye protection.** Protective equipment such as dust mask, non-skid safety shoes, hard hat, or hearing protection used for appropriate conditions will reduce personal injury.
- c) **Prevent unintentional starting. Ensure switch is in off-position before connecting to power source and/or battery pack, picking up, or carrying the tool.** Carrying power tools with your finger on the switch or energizing power tools that have the switch on invites accidents .
- d) **Remove any adjustment wrench or key before turning the power tool on.** A wrench or key left attached to a rotating part of the power tool may result in personal injury.
- e) **Do not overreach. Keep proper footing and balance at all times.** This enables better control of the power tool in unexpected situations .
- f) **Dress properly. Do not wear loose clothing or jewelry. Keep your hair, clothing and gloves away from moving parts.** Loose clothes, jewelry, or long hair can be caught in moving parts.
- g) **If devices are provided for the connection of dust extraction and collection facilities, ensure these are connected and properly used.** Use of dust collection can reduce dust related hazards. It is recommendation that the tool always be supplied via a residual current device with a rated residual current of 30mA or less.

4) Power tool use and care

- a) **Do not force the power tool. Use the correct power tool for your application.** The correct power tool will do the job better and safer at the rate for which it was designed .
- b) **Do not use the power tool if the switch does not turn it on and off.** Any power tool that cannot be controlled with the switch is dangerous and must be repaired .
- c) **Disconnect the plug from the power source and/or the battery pack from the power tool before making any adjustments, changing accessories or storing power tools.** Such preventative safety measures reduce the risk of starting the power tool accidentally.
- d) **Store idle power tools out of the reach of children and do not allow persons unfamiliar with the power tool or these instructions to operate the power tool.** Power tools are dangerous in the hands of untrained users.
- e) **Maintain power tools. Check for misalignment or binding of moving parts, breakage of parts and any other condition that may affect the power tool's operation. If damaged, have the power tool repaired before use.** Many accidents are caused by poorly maintained power tools .
- f) **Keep cutting tools sharp and clean.** Properly maintained cutting tools with sharp cutting edges are less likely to bind and are easier to control.
- g) **Use the power tool, accessories and tool bits ect. in accordance with these instructions , taking into account the working conditions and the work to be performed.** Use of the power tool for operations different from those intended could result in a hazardous situation.

5) Service

- a) **Have the power tool serviced by a qualified repair person using only identical replacement parts.** This will ensure that the safety of the power tool is maintained . If the supply cord is damaged, it must be replaced by the manufacturer, its service agent or similarly qualified persons in order to avoid a hazard.

Safety Warnings For Sanding Operations

1. This power tool is intended to function as a sander. Read all safety warnings, instructions and specifications provided with this power tool. Failure to follow all instructions listed below may result in electric shock, fire, or personal injury.
2. Operations such as grinding, wire brushing, polishing or cutting-off, are not recommended to be performed with this power tool. Operations for which the tool was not designed may create a hazard and cause personal injury.
3. Do not use accessories which are not specifically designed and recommended by the tool manufacturer. Just because the accessory can be attached to your power tool, it does not assure safe operation .
4. The rated speed of the accessory must be at least equal to the maximum speed marked on the power tool. Accessories running faster than their rated speed can break and fly apart .
5. The outside diameter and thickness of your accessory must be within the capacity rating of your power tool. Incorrectly sized accessories cannot be adequately guard or controlled.
6. The arbor size of wheels, flanges, backing pads or any other accessory must fit the spindle of the power tool. Accessories with arbor holes that do not match the mounting hardware of the power tool will run out of balance, vibrate excessively and may cause loss of control.
7. Do not use damaged accessory. Before each use inspect the accessory such as abrasive wheel for chips or cracks, backing pad for cracks, tear or excess wear, wire brush for loose or cracked wires . If power tool or accessory is dropped, inspect for damage or install an undamaged accessory. After inspecting or installing an accessory, position yourself or bystanders away from the plane of the rotating accessory and run the power tool at maximum no-load speed for one minute . Damaged accessories will normally break apart during this time .

8. Wear personal protective equipment. Depending on application, use face shield, safety goggles or safety glasses. As appropriate, wear dust mask, hearing protectors, gloves and workshop apron capable of stopping flying debris generated by various operations. The eye protection must be capable of stopping flying debris generated by various operations. The dust mask or respirator must be capable of filtering particles generated by your operations. Prolonged exposure to high intensity noise may cause hearing loss.
9. Keep bystanders a safe distance away from work area. Anyone entering the work area must wear personal protective equipment. Fragments of work piece or a broken accessory may fly away and cause injury beyond immediate area of operation.
10. Hold power tool by gripping insulated surfaces (handle) only, when performing an operation where the cutting accessory may contact hidden wiring or its own cord. Cutting accessory contacting a "live" wire may make exposed metal parts of the power tool "live" and shock the operator.
11. Position the cord clear of the spinning accessory. If you lose control, the cord may be cut or snagged and your arm or hand may be pulled into the spinning accessory.
12. Never lay the power tool down until the accessory has come to a complete stop. The spinning accessory may grab the surface and pull the power tool out of your control.
13. Do not run the power tool while carrying it at your side. Accidental contact with the spinning accessory could snag your clothing, pulling the accessory into your body.
14. Regularly clean the power tools air vents. The motor's fan will draw the dust inside the housing and excessive accumulation may cause electrical hazards.
15. Do not operate the power tool near flammable materials. Sparks could ignite these materials.
16. Do not use excessively oversized sanding disc paper. Follow manufacturer's recommendations when selecting sanding paper. Larger sanding paper extending beyond the sanding pad presents a laceration hazard and may cause snagging, tearing of the disc or kickback.
17. Risk of explosion. Floor sanding can result in an explosive mixture of fine dust and air. Use floor sanding machine only in a well-ventilated area free from any flame or match.

Kickback and Related Warnings

Kickback is a sudden reaction to a pinched or snagged rotating wheel, backing pad, brush or any other accessory. Pinching or snagging causes rapid stalling of the rotating backing pad which in turn causes uncontrolled power tool to be forced in the opposite direction of the backing pad's rotation at the point of the binding.

For example, if an abrasive wheel is snagged or pinched by the work piece, the edge of the wheel that is entering into the pinch point can dig into the surface of the material causing the wheel to climb out or kick out. The wheel may either jump toward or away from the operator, depending on direction of the wheel's movement at the point of pinching. Abrasive wheels may also break under these conditions.

Kickback is the result of power tool misuse and incorrect operating procedures or conditions and can be avoided by taking proper precautions as given below.

1. Maintain a firm grip on the power tool and position your body and arms to allow you to resist kickback forces. Always use auxiliary handles, if provided for maximum control over kickback or torque reactions during start up. The operator can control torque reactions or kickback forces, if proper precautions are taken.
2. Never place your hand near the rotating accessory. Accessory may kickback over your hand.
3. Do not position your body in the area where power tool will move if kickback occurs. Kickback will propel the tool in the direction opposite to the wheel's movement at the point of the snagging.
4. Use special care when working corners, sharp edges etc. Avoid bouncing and snagging the accessory. Corners, sharp edges or bouncing have a tendency to snag the rotating accessory and cause loss of control or kickback.

Additional Rules For Safe Operation

1. Empty the dust bag or dust collection receiver frequently. Do not leave residue in dust bag or dust collection receiver unattended. Always empty in a non-combustible metal container. Sanding wood or varnish produces dust that can self ignite and cause injury or damage. Follow this precaution for storage.
2. Set all exposed nails. Sweep loose abrasive away from work area. Do not strike metal pipes, ect., with sanding paper. Striking metal or abrasive particles with sanding paper produces sparks that could ignite the sanding dust which can cause injury or damage.
3. Do not operate a partially assembled power tool. Keep all adjustments within manufacturer's specifications. Keep all fasteners tight. Operating a partially assembled power tool could result in injury to the operator or bystander and could cause damage to the equipment or surroundings.
4. Do not attempt to change the sanding paper while the power tool is running. The sanding pad can snag clothing and cause injury to limbs and moving sanding paper can cause abrasions.
5. The power tool should only be used on an electrical system (mains) that is rated for the electrical requirements of the power tool as shown on the nameplate. Use only on an earthing (grounded) system. Do not service the power tool if it is energized or connected to an electrical circuit. Improper use could cause fire or electric shock.

Introduction

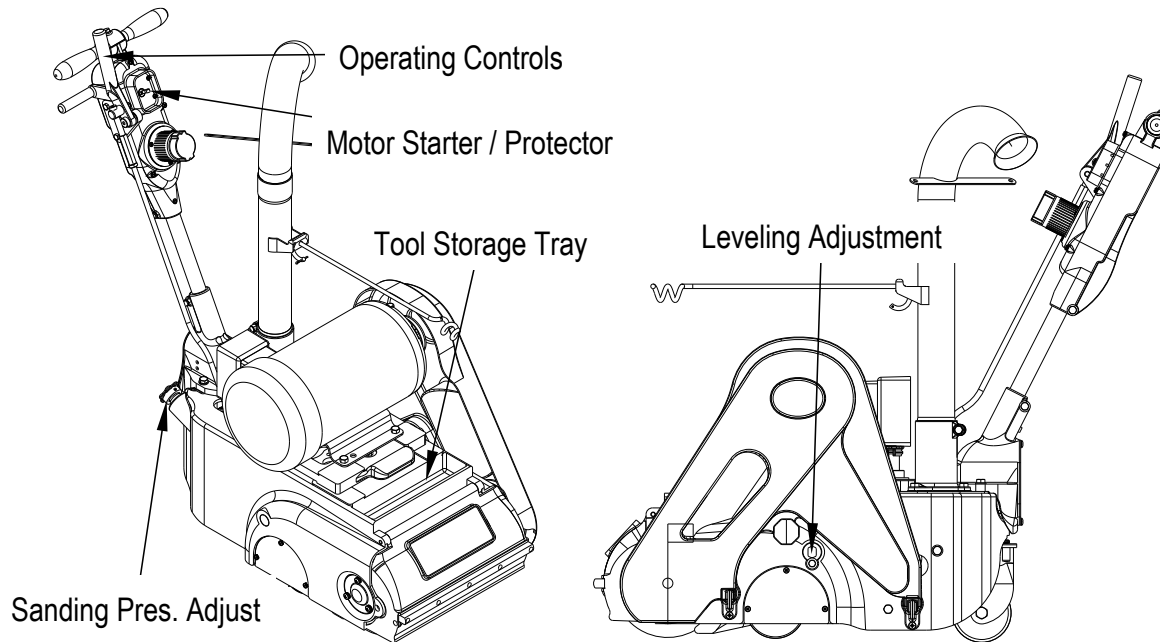

MODEL	07108A/07204A	07109A	07120A	07001A
Electrical Requirements	~208-240V 60 Hz	~220-240V 50 Hz	~220-240V 50 Hz	-230V 60 Hz 3Ø
Amperage	15.7	11.8	11.8	24
Sound Emission(Lpm)	83.0 dB(A)	79.4 dB(A)	79.4 dB(A)	83.0 dB(A)
Contact Wheel Rate(rpm)	2000/240	1670/200	1670/2000	2000/240
Abrasive Rate	3800/4560 ft/ min	970/1160 m/min	970/1160 m/min	3800/4560 ft/ min
Abrasive Sheet Size	280 CFM	970/1160 m/min	970/1160 m/min	3800/4560 ft/ min
Fan Flow Rate	12" x 26 1/8"	305mm x 664mm	305mm x 664mm	12" X 26 1/8"
Motor	4 Hp Continuous	2.2 kW Continuous	2.2 kW Continuous	10 Hp
Overload Protection	Magnetic Circuit Breaker	Magnetic Circuit Breaker	13 A Fuse	Magnetic Circuit Breaker
Operating Controls	Adjustable Lever/Grip	Adjustable Lever/Grip	Adjustable Lever/Grip	Adjustable Lever/Grip
Leveling Controls	Externally Adjustable	Externally Adjustable	Externally Adjustable	Externally Adjustable
Electrical Cable	100' 10-3 SJO with L6-20P Plug	H05VV3G4.0 AU3-20P Plug	H07RNF3G1.5 mm with UK1-13P Plug	N/A
Operating Wheels	80 Durometer Clear Urethane	80 Durometer Clear Urethane	80 Durometer Clear Urethane	80 Durometer Clear Urethane
Weight	240 lbs.	204 lbs.	92.7 kg	256 lbs
Dimensions	40 1/2" X 15 X 36 3/4"	40 1/2" X 15 X 36 3/4"	103cm x 38cm x 93cm	40 1/2" X 15 X 36 3/4"



CAUTION:

Your equipment may be inappropriate on some installations. Some softer woods used in flooring cannot support the pressure created by hard wheels. Always consult with the flooring manufacturer on the proper installation, preparation, and finishing of their product. Determine suitability of your equipment in preparing the product.

Electrical Connection Instructions

⚠ CAUTION: This machine will operate only on AC frequency and on electrical voltage shown on the equipment nameplate. Make sure you have the correct frequency and voltage before connecting the power cord to an outlet. See the example in figure 1.

This machine must be connected to an electrical source with an earthing conductor in order to protect the operator from electric shock. This machine has an approved power cord with three conductors as well as a plug with three terminals. Connect the plug to a matching receptacle.

⚠ DANGER: Electrocutation could occur if the machine is exposed to water or rain. Keep the machine in a dry building.

⚠ DANGER: Electrocutation could occur if machine is not connected to an electrical source with an earthing conductor. To prevent possible electric shock, use an electrical cord with an earthing conductor and connect it to a matching electrical source. For maximum protection against electrical shock, use a circuit that is protected by a ground fault circuit interrupter. Consult your electrical contractor.

⚠ DANGER: Electrocutation could occur if the machine is used with a damaged plug or power cord. If the cords or plugs are worn or damaged in any way, have them replaced by an authorized service person or electrician.

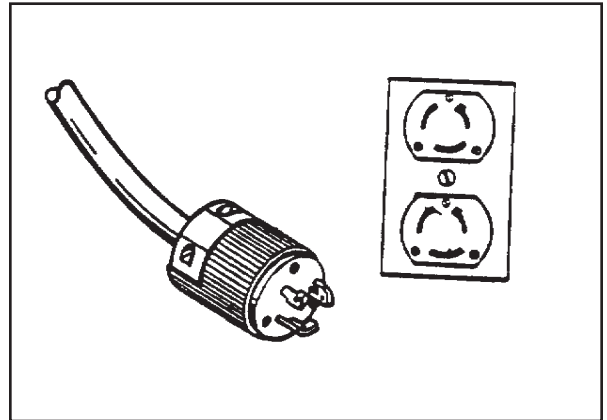

Figure 1

Extension Cords

Use only an approved three-pronged extension cord with two main conductors and one earthing conductor. This machine is equipped with a power cord. When greater range is needed follow the table below to determine cable gauge of additional footage. Refer to the chart to the right for extension cord information.

If motor appears to labor or takes a considerable longer time to come up to speed reduce sanding pressure.

Feet/Wire Gauge (Stranded Copper)

Source Voltage	0 - 100'	100 - 250'
208	6	Use Voltage Booster
230	10	8

Machine Transportation

⚠ WARNING: The machine is heavy. Remove the motor from the machine before transporting. Get help loading the machine and motor.

To transport the machine, follow this procedure:

1. Make sure the power cable is disconnected from the electrical outlet.
2. Disconnect the handle plug connection. See figure 1.
3. Remove the belt cover.
4. Remove the fan belt.
5. Loosen the motor bolt. Using the $\frac{3}{4}$ " wrench, turn the motor bolt counterclockwise. See figure 2.
6. Slide the motor forward.
7. Remove the drive belt.
8. Remove the motor from the chassis.

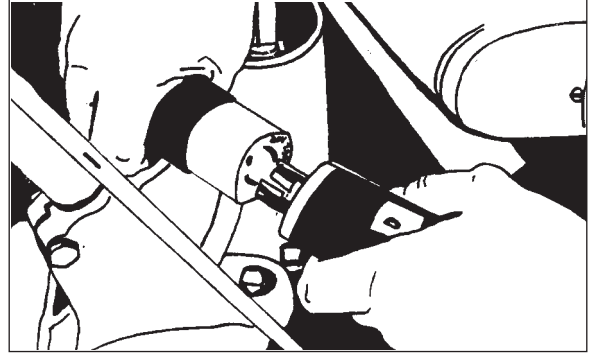

Figure 1

To re-assemble the machine after transporting, follow this procedure:

1. Reposition motor on chassis.
2. Install the drum belt. Slide the motor back until adequate tension is achieved in belt.

⚠ CAUTION: To prevent damage to the floor surface, make sure the drive belt is tight.

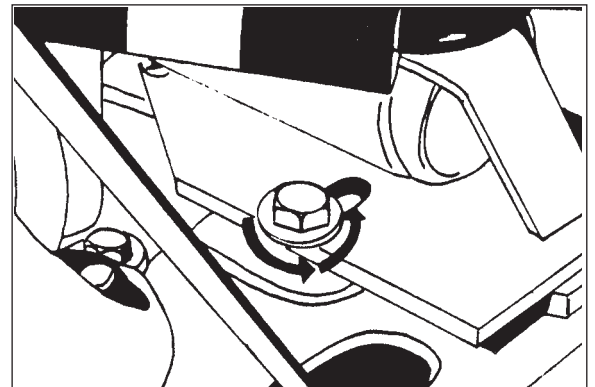

Figure 2

3. Resecure the motor to the chassis.
4. Install the fan belt.
5. Install the belt cover.
6. Reconnect the handle plug.

Machine Set-up

To set-up your machine follow this procedure:

1. Familiarize yourself with the machine and read all danger, warning and caution statements. Make sure all operators of this machine have read this Owner's Manual. If they cannot read English, have the manual explained fully before allowing anyone to operate the sander.
2. Locate the power supply. The receptacle should be compatible with the plug. The receptacle must be grounded and must be fused (30 amp) to avoid an electrical hazard.
3. Clip the dust bag to the elbow. Cross the strings on the dust bag and draw tight over the flare on the elbow. Wrap the string around the elbow and secure.
4. Wind the power cord through the cable arm. Keep the power cord out of path of equipment.

How To Install The Abrasive

 **WARNING:** Disconnect power before changing abrasive.

To install the abrasive, follow this procedure:

1. Prepare abrasive with template supplied.
2. Place backing of abrasive on the template. The template is marked "This Side Up." Make sure the marked side of the template is facing up.
3. Cut the abrasive to the exact length of the template.
4. Align one edge of the abrasive with a notch in the template.
5. Fold the other end of the abrasive over the end of the template and crease.
6. Repeat steps 4 and 5 for remaining notch.
7. Lift the drum cover.
8. Put the smooth side of the abrasive against the sanding drum.
9. Put one end of the abrasive against the sanding drum slot (1). See figure 3.
10. Turn the drum one revolution. Put the other end of the abrasive in the drum slot (2). See figure 3.

11. Tighten the abrasive.

To tighten the abrasive, follow this procedure:

1. The end wrenches are given with the machine. Put a wrench around the nut at each end of the drum (1). See figure 4.
2. Make sure the flat sides of the nuts are parallel with the drum slot.
3. Turn the wrenches the opposite rotation until the abrasive is tight against the drum (2). See figure 4.

12. Remove the end wrenches.

13. Close the cover.

NOTE: When using #4 or 4½ grit abrasive, remove the large grains from the folded ends. To remove the grains, rub the folded ends together.

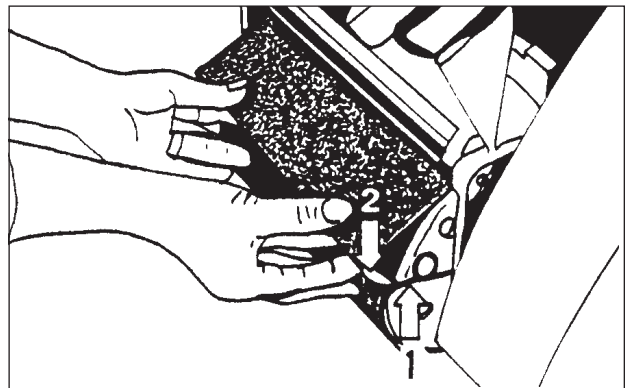

Figure 3

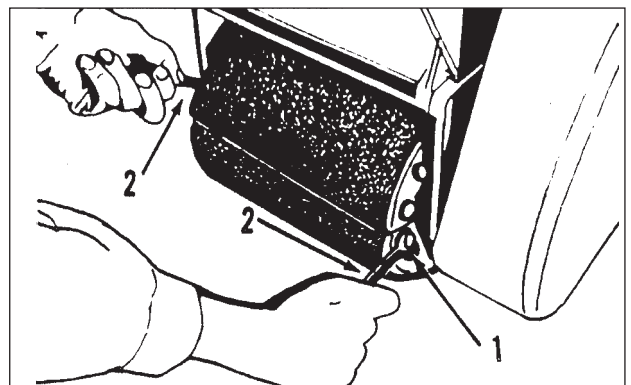

Figure 4

Operating Instructions



DANGER:

Sanding/finishing wood floors can create an environment that can be explosive. Cigarette lighters, pilot lights and any other source of ignition can create an explosion when active during a sanding session. All sources of ignition should be extinguished or removed entirely if possible from the work area.



DANGER:

Work areas that are poorly ventilated can create an explosive environment when certain combustible materials are in the atmosphere, i.e., solvents, thinners, alcohol, fuels, certain finishes, wood dust and other combustible materials. Floor sanding machines can cause flammable material and vapors to ignite. Read the manufacturer's label on all chemicals used to determine combustibility. Keep the work area well ventilated.



DANGER:

Sanding dust can spontaneously ignite and cause an injury or damage. Sanding dust should be disposed of properly. Always empty the sanding dust into a metal container. Remove the contents of the dust bag when the bag is 1/3 full.



DANGER:

Sanding dust can spontaneously ignite and cause an injury or damage. Remove the contents of the dust bag each time you finish using the machine. Always dispose of the dust in a metal container located outside of the building. Never leave a dust bag unattended with sanding dust in it. Do not empty the contents of the dust bag into a fire.



DANGER:

Hitting a nail while sanding can cause sparks and create an explosion or fire. Always use a hammer and punch to countersink all nails before sanding floors.

Operating Instructions

1. Install the operator's belt as follows:
 - a. Position the operator's belt around waist.
 - b. Cross the straps at the waist. See figure 5.
 - c. Slide the belt loop end over the handle on the control lever side. Adjust the length as needed.
 - d. Wrap the remaining strap around the opposite side of the handle and hold it in place with your hand.



WARNING: Should quick release of the machine be necessary, serious operator injury could occur if the operator has tied the loose end of the operator's belt strap to the machine. Always position the strap so that you can let go and get away quick in case of bag fire or explosion.

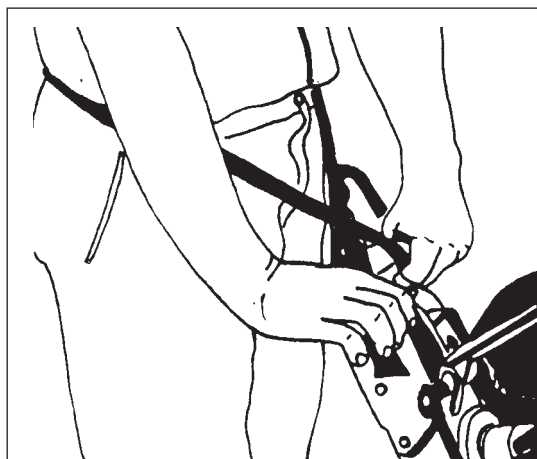

Figure 5

2. Put the On/Off switch into the "ON" position.



DANGER: Serious damage can occur to the floor surface if the machine is not in motion while the contact wheel is running on the floor surface. To prevent damage to the surface, make sure the machine is always moving when the contact wheel is in contact with the floor.

3. Work right to left. For each forward pass, move the machine 4" over the pass you have just finished. Retrace your reverse path without overlapping. See figure 6.
4. Feather-cut in by easing the contact wheel down onto the surface with the control lever while the sander is in motion.
5. When contact wheel is fully engaged with the surface, gradually adjust your pace for adequate finish removal. Keep sander in motion while the contact wheel is engaged with the surface or dwell marks will occur.
6. Move the machine in the direction of the grain in the wood whenever it is possible. Sand the surface at a constant pace.
7. Gradually feather-cut out at the termination point (the end of your pass) by easing the contact wheel up with the control lever. Stagger the termination points for a better blend when edging.
8. Empty dust bag whenever it is 1/3 full. Never leave a dust bag unattended with sanding dust in it. Sanding dust can spontaneously ignite and cause a fire or explosion. Empty dust into a metal container located outside of the building.

Operating Instructions

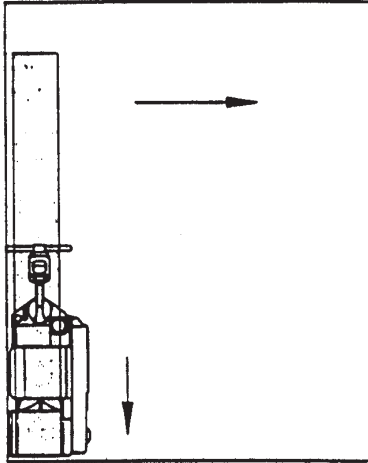

A. First pass forward, right to left.

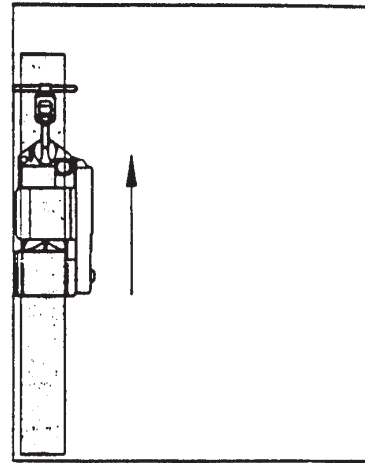

B. First pass reverse, retrace same path.

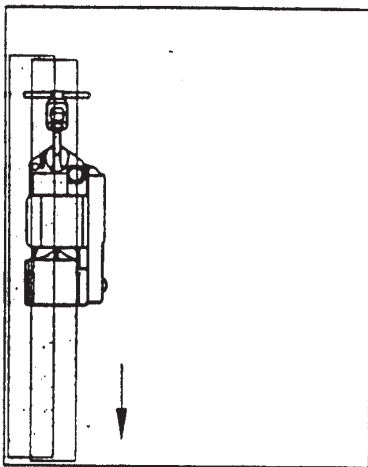

C. Second pass forward, overlap $\frac{1}{2}$ the drum width.

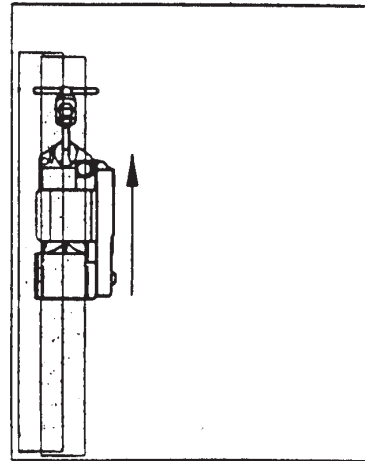

D. Second pass reverse, retrace second path forward, etc....for the entire room

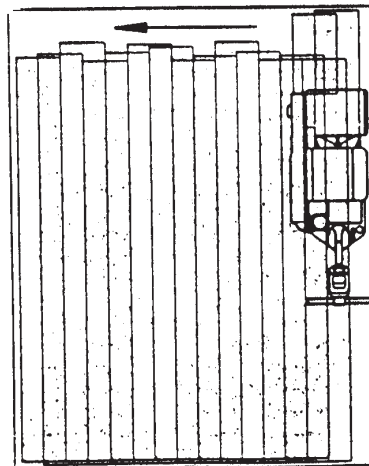

E. Work the remaining unsanded floor in the same fashion, right to left.

Figure 6

Sanding Cuts and Sandpaper

Initial Cut

The purpose of the initial cut is to remove old finish and gross imperfections on the floor surface. The sanding equipment should be adjusted to heavy sanding pressure setting and a coarse abrasive should be used. If the surface is severely damaged by deep scratches, pre-existing dwell marks, uneven planks, etc., it may be necessary to sand across or diagonally to the grain to restore evenness to the surface. If these conditions are not present, the initial cut should be done in the direction of the grain.

If glazing, loading, or burning takes place immediately into an initial cut, select a coarser abrasive. If this should occur during an initial cut, the abrasive has dulled and must be replaced.

Final Cuts

The purpose of a finishing cut is to remove the scratches produced during the initial cut. Use a fine (60 - 80 grit) grain abrasive and a reduced sanding pressure setting.

If the surface remains rough after a finishing cut, it may be necessary to use an even finer grain of abrasive (80 - 100 grit). Care should be taken in selecting the grit size of the abrasive. A very fine grain will close the pores on a wood floor making admission of a stain difficult.

If glazing or burning should occur immediately into a finishing cut, reduce the sanding pressure. If it should occur during a finishing cut, the abrasive has dulled and must be replaced.

Sander Adjustment Procedures



DANGER:

Electrocution could occur if maintenance and repairs are performed on a unit that is not properly disconnected from the power source. Disconnect the power supply before attempting any maintenance or service.



DANGER:

Moving parts of this machine can cause serious injury and/or damage. Keep hands, feet and loose clothing away from all moving parts of the sander.

Sanding Pressure

To adjust the sanding pressure follow this procedure:

1. Screw the sanding pressure knob down to increase the sanding pressure when making the roughing in cut.
2. Screw the sanding pressure knob up to decrease the sanding pressure when making the finishing cut.

Drum Rates

The machine can be operated at two rates. To change the speed of the drum, follow this procedure:

1. Remove the belt cover.
2. Remove the fan belt.
3. Loosen the motor bolt.
4. Slide the motor forward.
5. For high drum rates, install drive belt in larger diameter of the grooves available on the motor pulley and in the smaller diameter of the two grooves available on the drum pulley. For lower rates, install drive belt in smaller diameter of the grooves available on the motor pulley and in the larger diameter of the two grooves available on the drum pulley.
6. Tighten belt and secure motor to chassis.
7. Install the fan belt.
8. Install the belt guard.

Sander Adjustment Procedures

Leveling

If the sanding drum is out of adjustment, follow this procedure:

1. Remove the belt cover.
2. Loosen the eccentric lock screw. Using the 7/16" wrench, turn the eccentric lock screw (1) counterclockwise. See figure 7.
3. To raise or lower the drum, turn the eccentric (2). See figure 7.
4. Tighten the eccentric lock screw. To tighten the eccentric lock screw, turn the screw clockwise.
5. Install the belt cover.

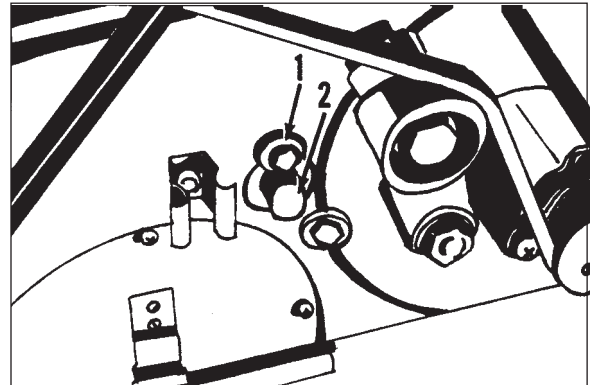

Figure 7

How to Lubricate the Wheel Pivots

NOTE: The wheel pivots must be lubricated after every 25 hours of use.

To lubricate the wheel pivots, follow this procedure:

1. Put the machine on its side.
2. Lubricate the pivots. The pivots are behind the truck wheels. See figure 8.
3. Put the machine on its wheels.

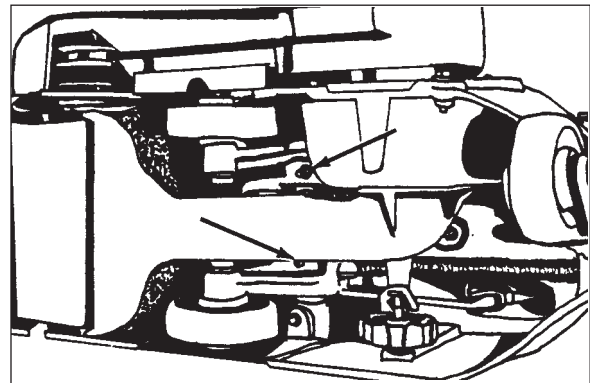

Figure 8

Operating Control

To increase the travel or extend the reach on the grip control follow this procedure:

1. Loosen the locknut on the control rod. See figure 9.
2. Screw the control rod adjuster in until the desired reach is found.
3. Tighten the locknut.

To decrease the travel or reduce the reach on the grip control follow this procedure:

1. Loosen the locknut on the control rod. See figure 9.
2. Screw the control rod adjuster out until desired reach is found.
3. Tighten the locknut.

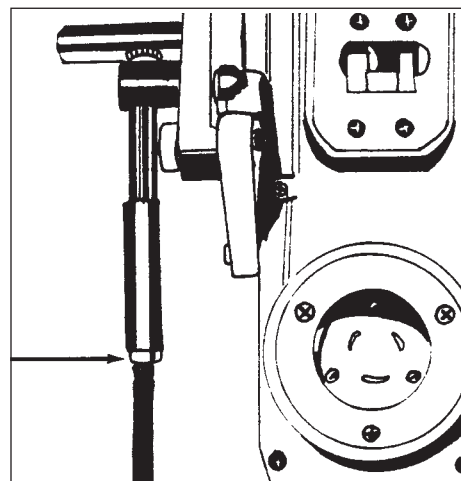

Figure 9

Routine Maintenance

The following items need to be periodically inspected and maintained to keep your sander in good working condition.

Wheels

Periodically remove the debris from the truck and caster wheels. Debris can cause waves on a sanded surface. Lubricate truck mechanism every 25 hours of use. The machine is equipped with lubrication fittings and are located on shaft supporting mechanism.

Dust Bag

Remove the dust bag from the machine and shake it thoroughly to remove the sanding dust from the dust bag. Turn the dust bag inside out and machine wash in cold water to prevent pore blockage and loss of dust recovery.

Drive Belt

Periodically check the drive belt tension.

Bearings

Periodically check the bearings for wear or damage according to the following schedule:

Idler pulley..... after 1st 1500 hrs.
Fan shaft after 1st 2500 hrs.
Arbor shaft after 1st 5000 hrs.
Motor shaft after 1st 5000 hrs.

Troubleshooting

PROBLEM	CAUSE	ACTION
Drive belts slip.	Insufficient tension. Worn belts.	Tension drive belt. (Squeaking or squealing sound) Replace belts.
Squealing, growling or grinding noise coming from machine.	Damaged and/or worn bearing.	Remove drive belts, rotate arbor motor, fan, shafts and idler pulley to locate dragging or rough bearing. Contact an authorized American Sanders dealer.
Dust pick-up is poor.	Dust bag is over 1/3 full. Dust bag is dirty. Dust chute is obstructed.	Empty contents of bag. Shake debris from bag and wash. Remove fan cover and clear throat.
Motor will not start.	Defective motor starter. Defective start capacitor. Defective electronic start switch. Low voltage from poor connection. Defective motor. No power.	Contact an authorized American Sanders dealer. Contact an authorized American Sanders dealer. Contact an authorized American Sanders dealer. Contact an authorized American Sanders dealer. Contact an authorized American Sanders dealer. Check power supply and connections.
Motor runs sluggishly.	Low voltage from excessive footage, undersized extension cord, or poor connection. Defective run capacitor. Defective motor.	Locate power source nearer to work site. Decrease sanding pressure. Contact an authorized American Sanders dealer. Contact an authorized American Sanders dealer.
Motor starter trips/repeatedly	Excessive load. Defective electronic start switch. Defective motor starter. Low voltage from poor connection. Defective motor Defective capacitor.	Contact an authorized American Sanders dealer. Contact an authorized American Sanders dealer. Contact an authorized American Sanders dealer. Contact an authorized American Sanders dealer. Contact an authorized American Sanders dealer. Contact an authorized American Sanders dealer.
Uneven cut.	Leveling out of adjustment.	Readjust leveling.
Burning or glazing.	Dull abrasive. Excessive sanding pressure. Too fine of an abrasive.	Replace abrasive. Decrease sanding pressure setting. Use coarser abrasive.
Slow cutting.	Dull abrasive. Too fine of an abrasive. Insufficient sanding pressure.	Replace abrasive. Use a coarser abrasive. Increase sanding pressure setting.
Waves on sanded surface.	Debris on wheel. Flat spot on tire(s).	Remove and clean wheels. Replace tires.
Chatter marks on sanded	Drum out of round. Surface (close evenly spaced) Drum vibration.	Contact an authorized American Sanders dealer or replace the drum. Change shim combination. Remove debris from surface or ends of drum.